

CAD FILE:

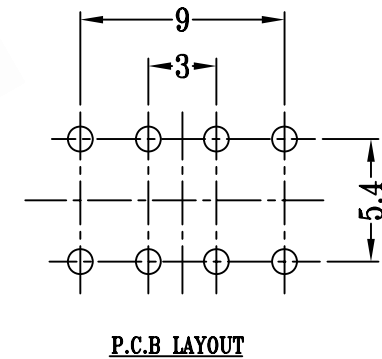
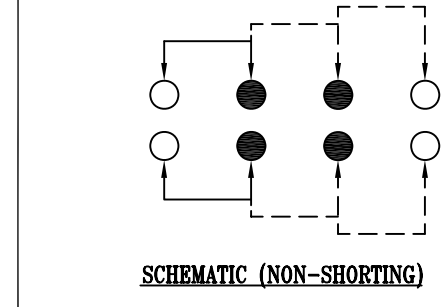
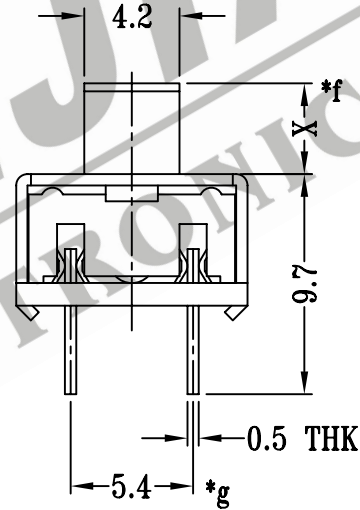
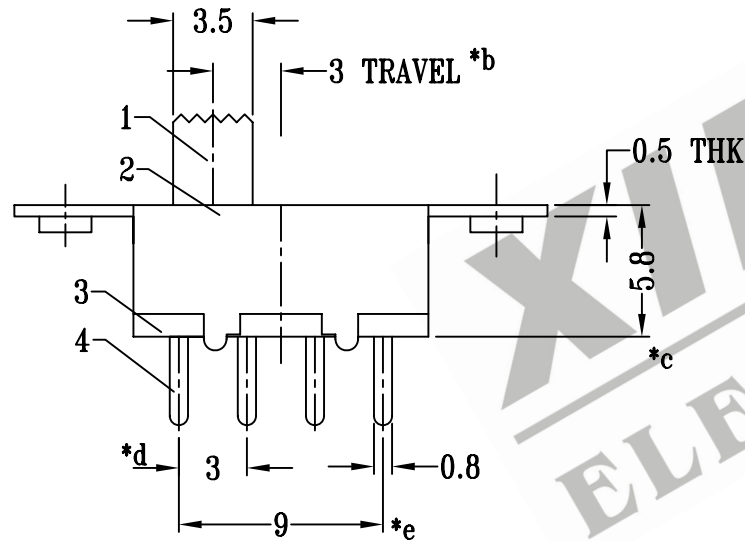
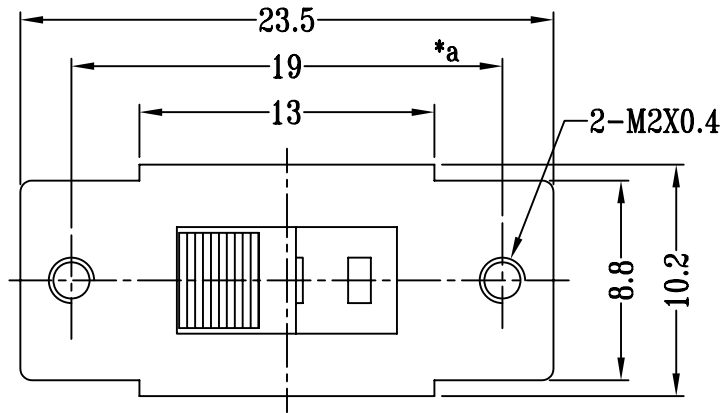

注:带"*"表示关键尺寸(7个)

8					TOLERANCE UNLESS SPECIFIED	SHENZHEN XIEJIA ELECTRONICS CO.,LTD.				
7	STEEL BALL	STEEL	1	NATURAL						
6	SPRING	STEEL WIRE	1	TEMPER	WITHIN: 1.5±0.1mm OVER: 1.5±0.2mm	ISSUE	DATE	DESCRIPTIONS OF REVISION		APPD.
5	CONTACT CLIP	PBS STRIP	2	Ag PLATED						
4	TERMINAL	BRASS STRIP	8	Ag PLATED OVER Ni PLATED	TITLE : VERTICAL SLIDE SWITCH	UNIT : mm	DRWG NO.: XJ-DR-SS23F36-00			
3	BASE	PHENOLIC RESIN	1	NATURAL	MODEL: SS-23F36	SCALE: 3:1	DWN.	ZHOUYU	2005-7-5	
2	FRAME	STEEL STRIP	1	Ni PLATED			CHK'D	FANGYING	2005-7-5	
1	KNOB	POM	1	BLACK	ALL MATERIALS MUST BE COMPLIANT TO ROHS	APPD.	KANGXINAN	2005-7-5		
NO.	PARTS	MATERIALS	Q'TY	FINISH						